



Coe Lanie



RICHARDS BAY

Procedure No.

SOP 05 HT

Revision

0

Pages

1 OF 2

SOP 05 HT- HEDGE TRIMMER

TABLE OF CONTENTS

1. PURPOSE.....	2
2. SCOPE.....	2
3. RESPONSIBILITY, ACCOUNTABILITY AND AUTHORISATION.....	2
4. DEFINITIONS & ABBREVIATIONS.....	2
5. SAFETY, HEALTH, ENVIROMENTAL & QUALITY.....	2
6. PROCEDURE.....	2
7. RECORDS.....	2

REVISION SHEET

REVISION NUMBER	SUBJECT OF REVISION	PAGE NUMBER	EFFECTIVE DATE
0	New Procedure	All	16/07/2010

ENDORSEMENT

	DESIGNATION	DATE	SIGNATURE
REVIEWED BY	OWNER	16/7/10	
CHECKED BY	OWNER	16/7/10	
APPROVED BY	OWNER	16/7/10	



DUST MASK
MUST BE WORN



EYE & HEARING
PROTECTION
MUST BE WORN



PROTECTIVE
CLOTHING
MUST BE WORN



FOOT
PROTECTION
MUST BE WORN



HAND
PROTECTION
MUST BE WORN

To ensure the safe operating of a hedge trimmer

2. SCOPE

Applies to all blower operators

3. RESPONSIBILITY, ACCOUNTABILITY AND AUTHORISATION

The Supervisor /operator to be convinced that the procedure poses no threat to himself, other people, surrounding buildings and or vehicles. Ensure that no person or animal is endangered when operating the hedge trimmer.

4. DEFINITIONS & ABBREVIATIONS

None

**5. SAFETY, HEALTH, ENVIROMENTAL & QUALITY
ALWAYS WEAR PERSONAL PROTECTIVE**

6. PROCEDURE

1. Employees will be properly trained before attempting to do any work with a hedge trimmer.
2. Thoroughly inspect the hedge trimmer every morning before each shift starts.
3. Inspect the area and remove foreign objects, check for electrical wire ect.
4. ALWAYS use both hands when starting a hedge trimmer, one to hold the machine and the other to pull the starter rope.
5. Always hold the unit firmly with both hands on the handles. Wrap your fingers and thumbs around the handles.
1. ALWAYS start the engine at least 3 meters from the fueling spot, outdoors only. Place the unit on firm ground in an open area. Make sure you have good balance and secure footing. Hold the unit securely. The cutting blades must be clear of the ground and all other obstructions because they may begin to run when the engine starts.
2. Make sure the muffler side of the engine is away from your body to avoid burns.
3. Maintain a proper balance and secure footing. Do not work on slippery, uneven or unstable surfaces. Do not work in odd positions.
4. To reduce the risk of injury, avoid contact with the cutting blades. Left hand on the control handle and right hand on the front handle. Make sure you have firm and secure footing and hold the unit so that the cutting blades are always away from your body. Watch the cutting blades at all times – do not cut areas of the hedge that you cannot see.
5. Note that the cutting blades continue to run for a short period after you let go of the throttle trigger (flywheel effect).
6. Allow the engine and muffler to completely cool before refuelling or performing any maintenance work.

7. RECORDS

None

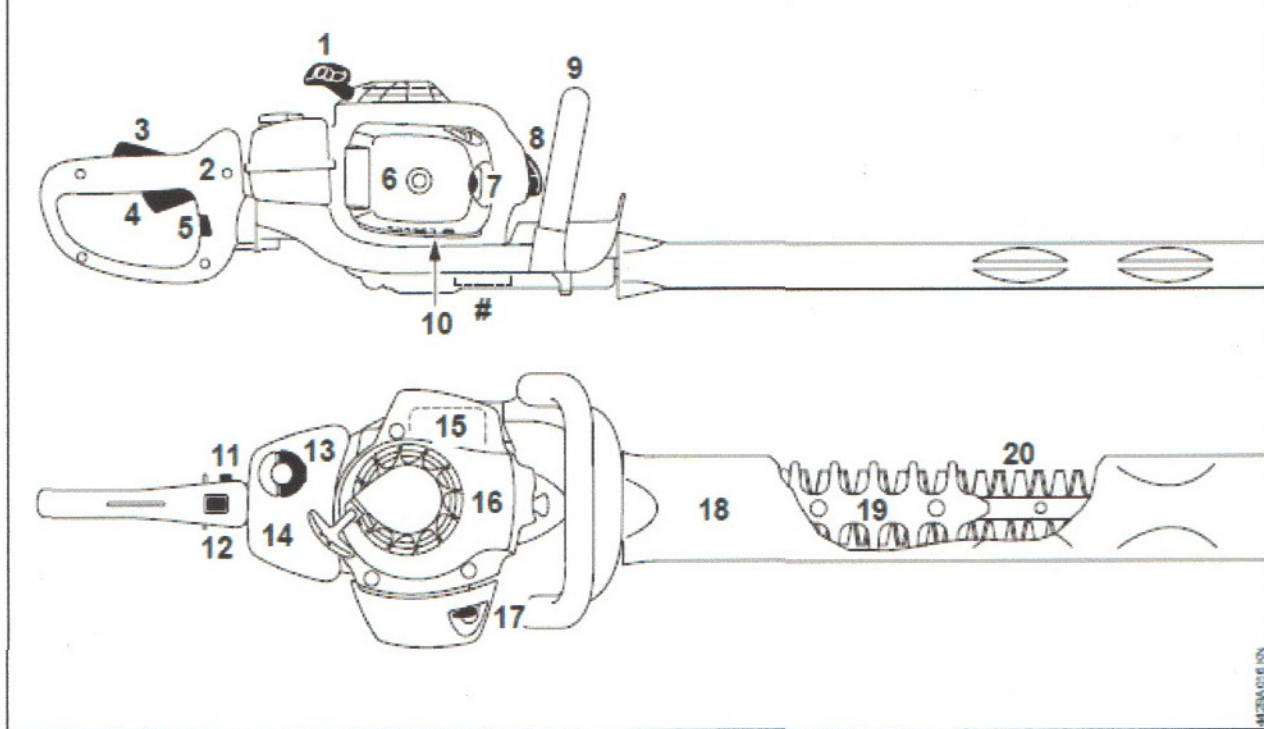

- 1 Starter grip
- 2 Rear handle
- 3 Interlock lever
- 4 Throttle trigger
- 5 Twist lock
- 6 Filter cover
- 7 Manual fuel pump
- 8 Spark plug boot
- 9 Front handle
- 10 Carburetor adjusting screws
- 11 Starting throttle button
- 12 Stop switch
- 13 Fuel filler cap
- 14 Fuel tank
- 15 Muffler
- 16 Fan housing
- 17 Choke lever
- 18 Blade scabbard
- 19 Cutting blade guard
- 20 Cutting blades
- # Serial number



Swing the cutting blade from the bottom upwards in an arc – lower the nose of the blade, move along the hedge and then swing the blade up again in an arc.



Hold the cutter bar at an angle of 0° to 10° as you swing the hedge trimmer horizontally.

Swing the cutting blade in an arc towards the outside of the hedge so that the cuttings are swept to the ground.

Holding and Controlling the Unit

Always hold the unit firmly with both hands on the handles. Wrap your fingers and thumbs around the handles.

Right-handers

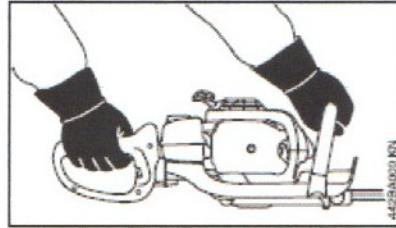

Right hand on the control handle and left hand on the front handle.